

VEHICLE GATE OPEN RING DETAIL, PLAN (A)

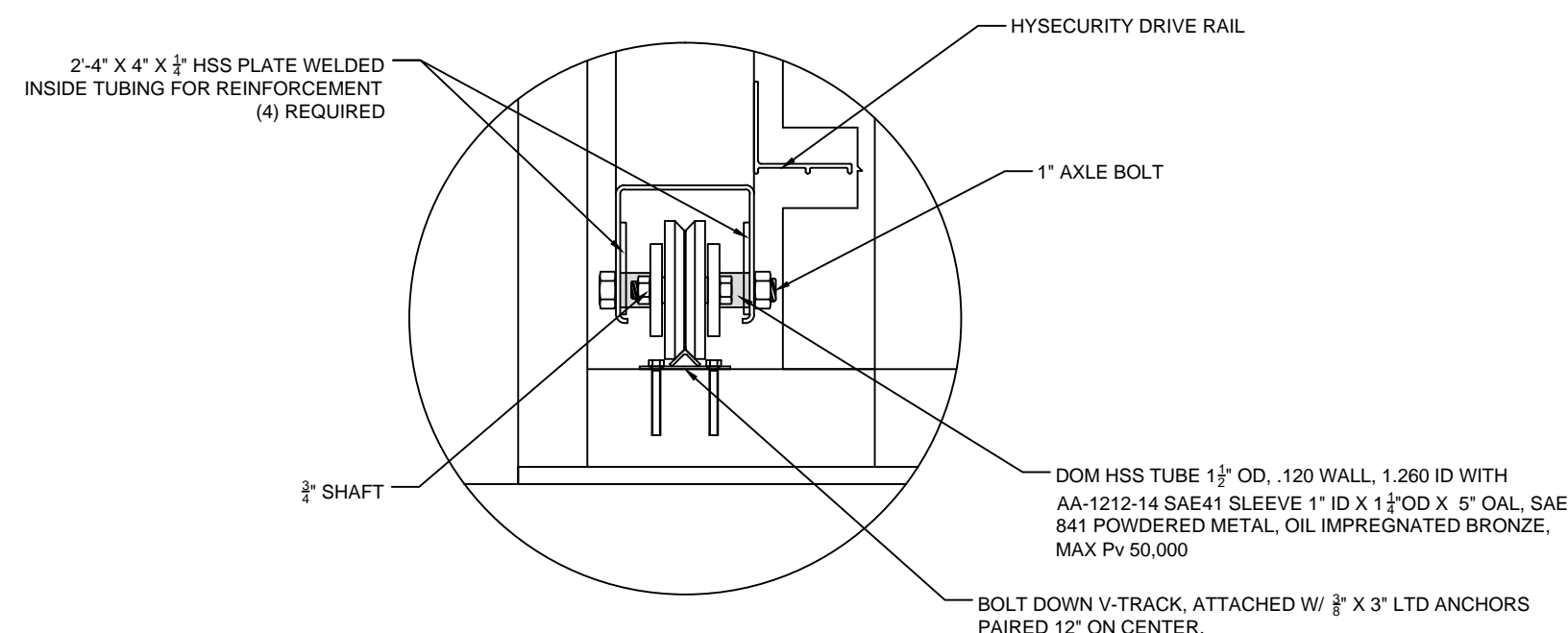

TROLLEY ASSEMBLY ELEVATION DETAILS

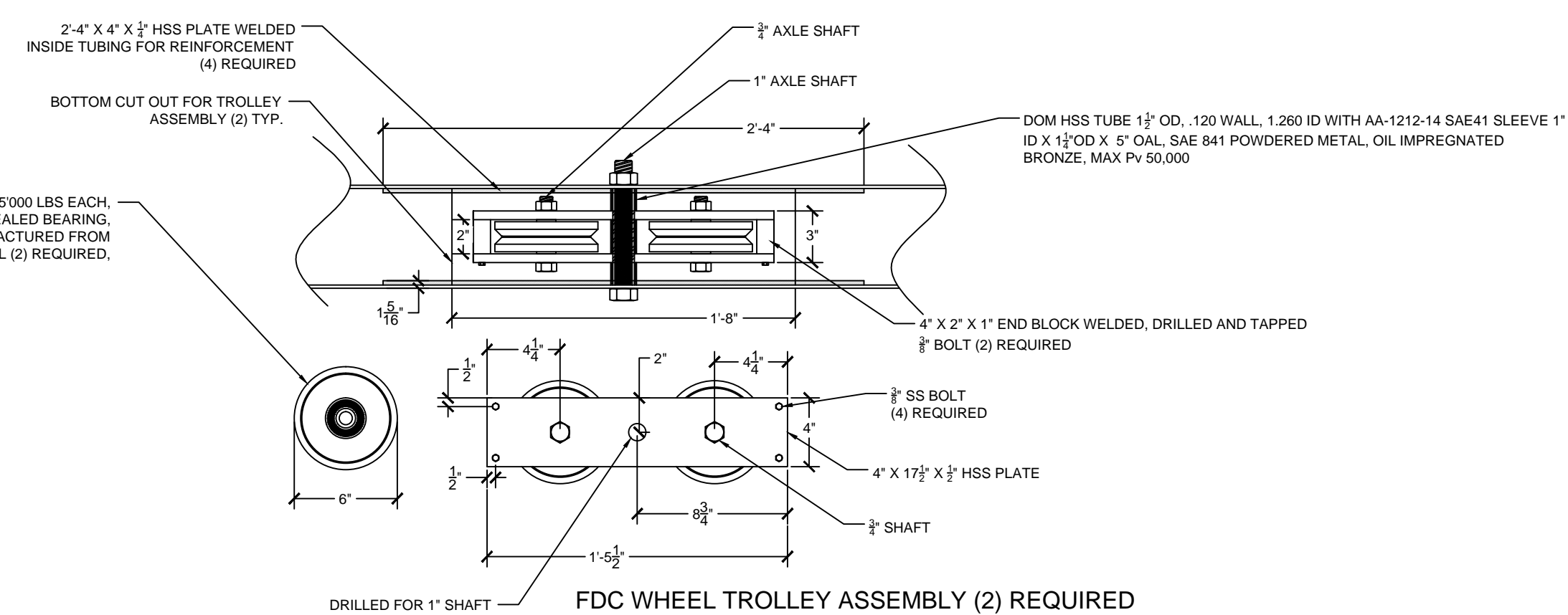

FDC WHEEL TROLLEY ASSEMBLY (2) REQUIRED

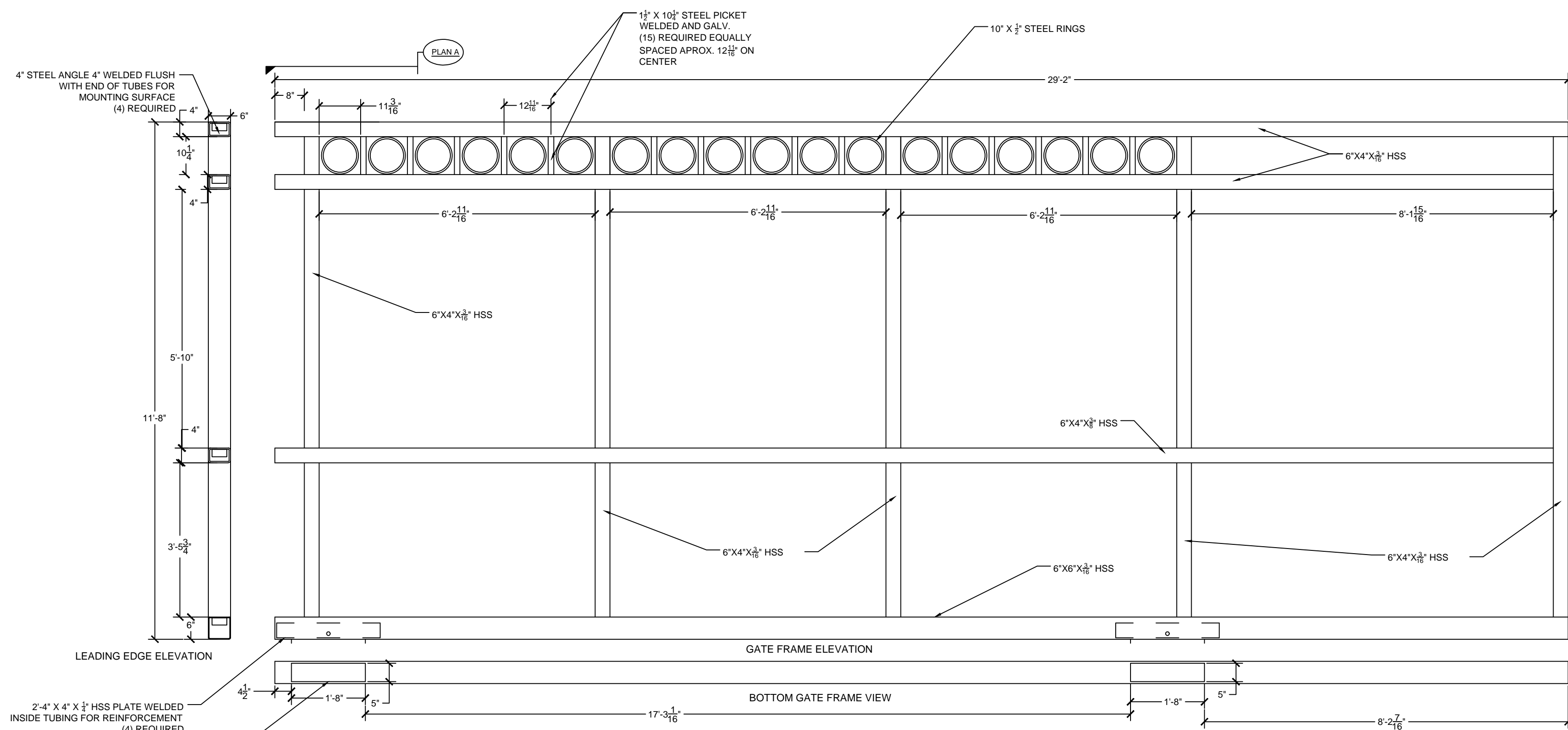

VEHICLE GATE FRAMING DETAILS

HOT DIPPED, GALVANIZED THEN PAINTED PER APPROVED SUBMITTALS.

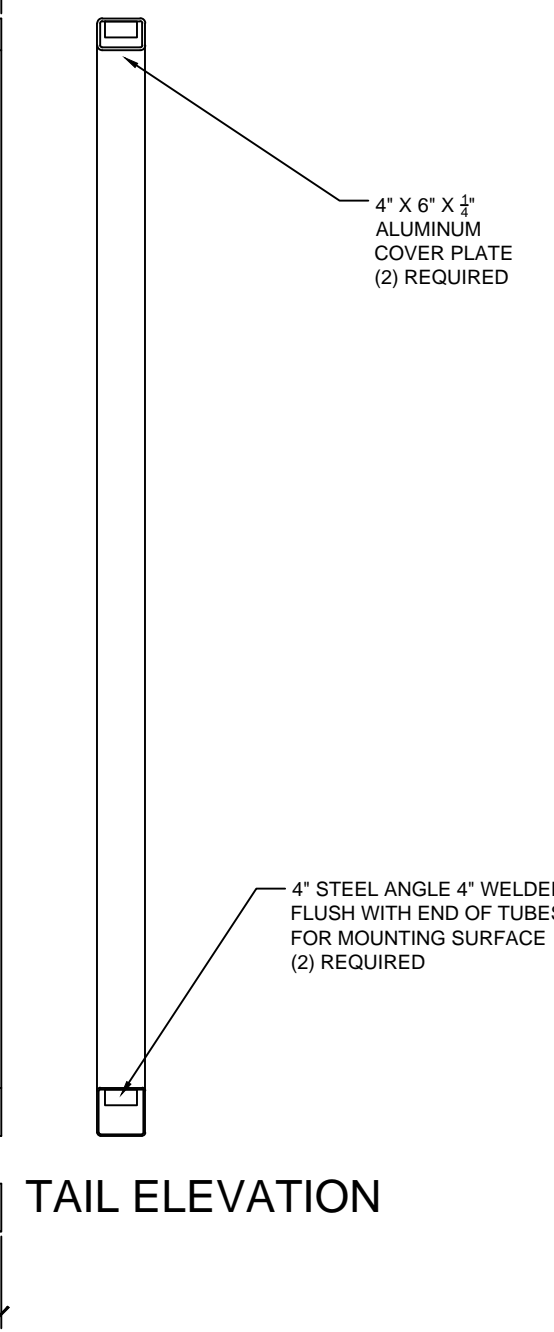

TAIL ELEVATION

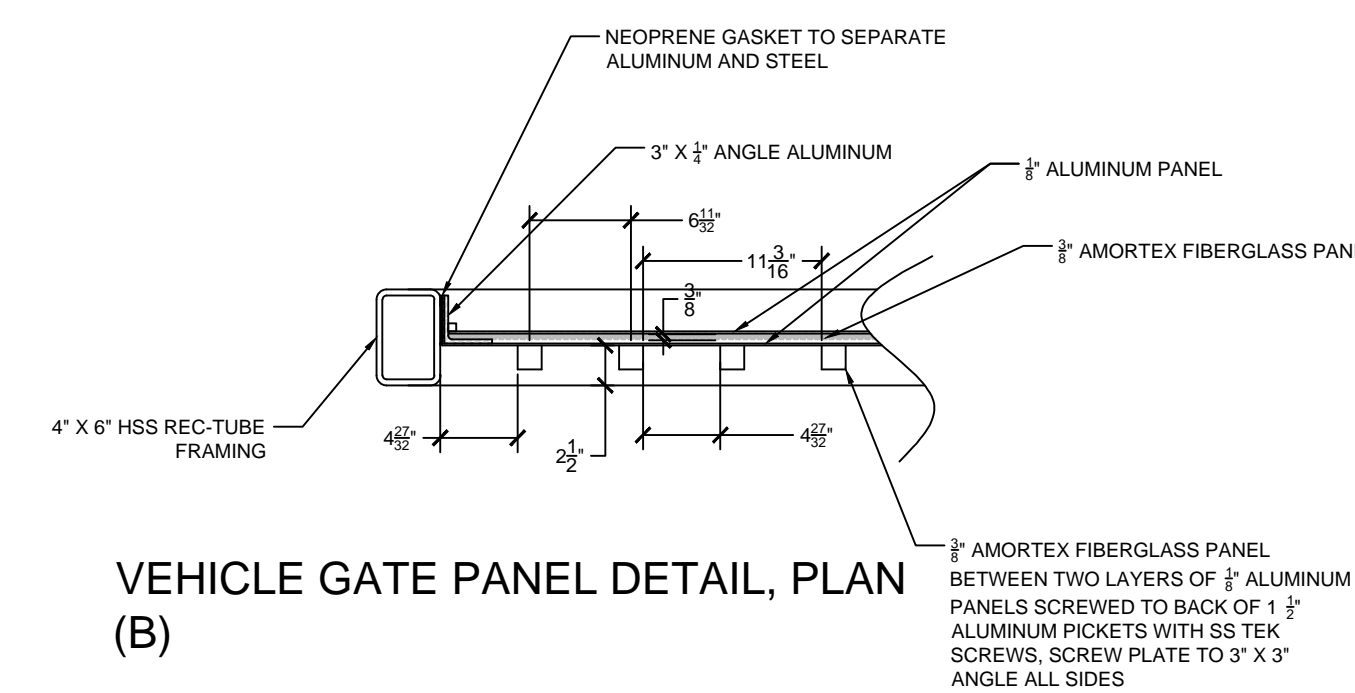

VEHICLE GATE PANEL DETAIL, PLAN (B)

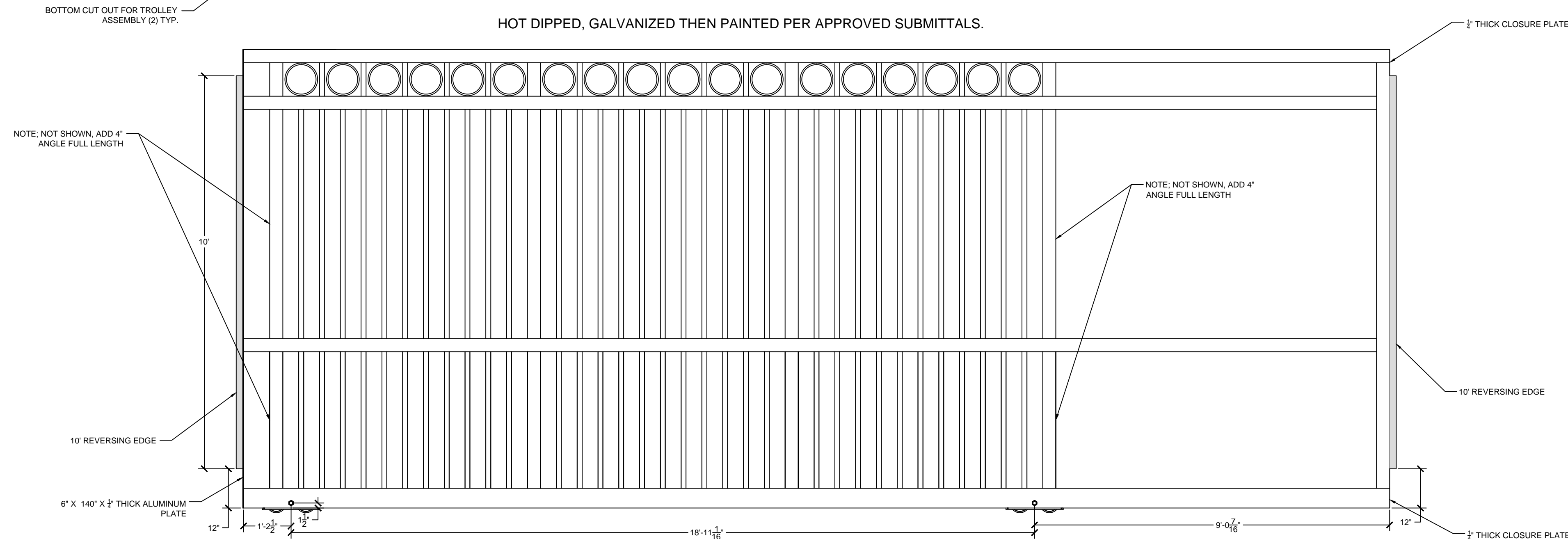

20' VEHICLE SLIDE GATE DETAILS, ELEVATION

NOTE: PAINTED PER APPROVED SUBMITTALS.

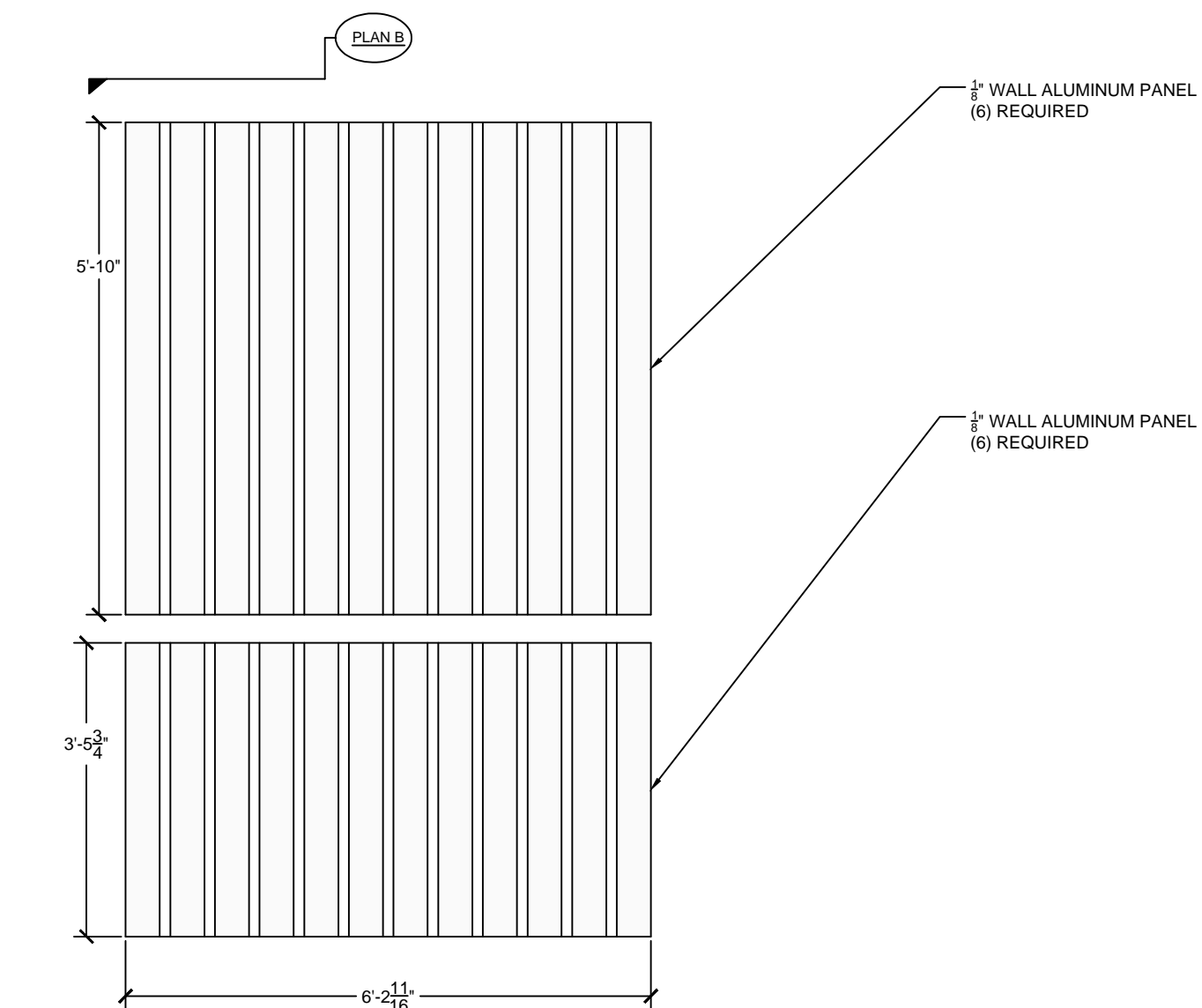

VEHICLE GATE FRAMING PANEL DETAILS

# FDC STRONGWELD BALLISTIC SLIDE GATE SYSTEM

DOUBLE CLEAR OPENINGS UP TO 40'  
MATCHED WITH HYSECURITY SLIDEDRIVER 80 GATE OPERATOR  
(SEE SPECIFICATIONS PROVIDED ON SHEET 2)

DOUBLE CLEAR OPENINGS UP TO 100'  
MATCHED WITH HYSECURITY SLIDEDRIVER 200 GATE OPERATOR  
(SEE SPECIFICATIONS PROVIDED ON SHEET 2)

<b>FDC</b> Florida Door Control Melbourne, FL. 32934	
FDC STRONGWELD BALLISTIC SLIDE GATE SYSTEM	
PART NO.	JOB NO.
DWG. NO. FSBSG1	SCALE N/A BY: BRAWN S.T.
DATE 01/04/2021	SHEET 1 OF 2

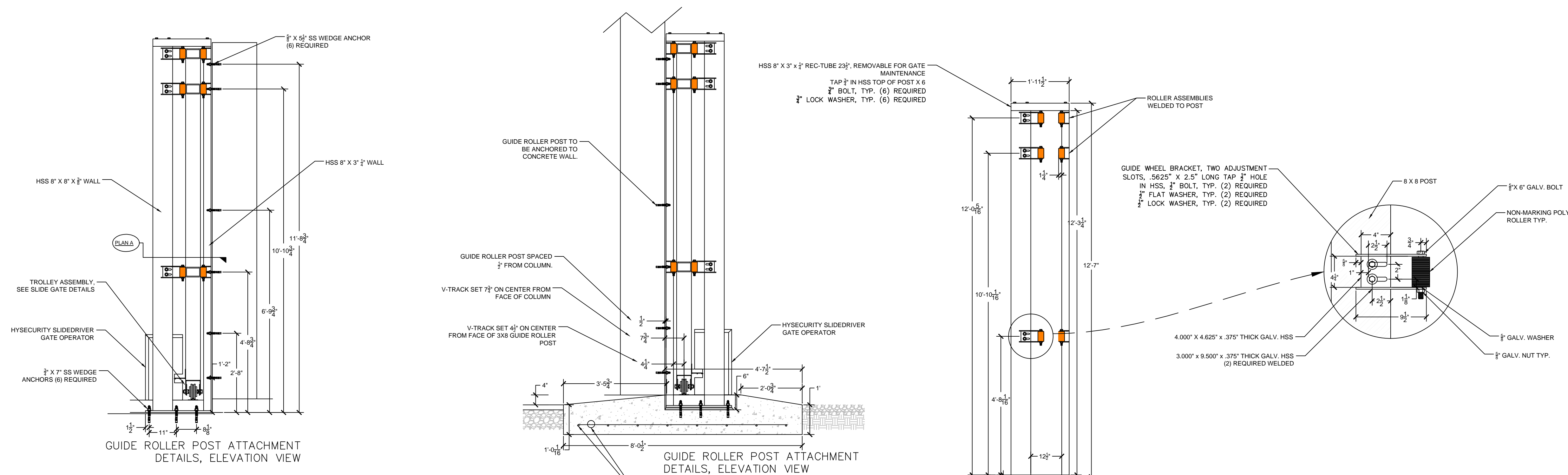

HySecurity SlideDriver 80	
Capacity	8,000 lb gates 1 ft/s
Model	SlideDriver 80
Part #	222 XLS1
Duty Cycle	Continuous
Horsepower	2 hp
Drive	Hydraulic
Drive Wheels	One 8 inch (20 cm) AdvanceDrive wheel, One 8 inch XtremeDrive wheel and 27 ft (8 m) of rack
Gate Weight Max.	8,000 lb (3,629 kg)
Gate Length Max.	Limited only by weight
Drawbar Pull	600 lb (272 kg)
Rate of Travel	1 ft/s (30 cm/s)
Temperature Rating	-40° to 158°F (-40° to 70° C)
1 Phase Power	208/230V 60 Hz 20V 50 Hz***
3 Phase Power	208/230V 60 Hz 20V 50 Hz***
Included Accessories	One premium BAR 18-MON photo eye, one 5-foot premium ACO edge sensor and a pre-wired Hy2NC adapter
Communication	RS-232, RS-485, Ethernet/Fiber using optional HyNet™ Gateway accessory
User Controls	Smart Touch Controller with 70+ configurable settings, programmed via the keypad and display or a PC using S.T.A.R.T. software
Relay	Three configurable user relays: one 30VDC, 3A solid state and two 250VAC, 10A electromechanical; Optional HyRelay™ for 8 additional relay outputs
Finish	Zinc plated with powder coating
UL Listed (UL 325)	Usage Class III, IV
Warranty	5 year w/product registration
UPS Battery Backup Power and Additional Models	
DC Power Supply* 1 with HyCharger DC	SlideDriver 80 UPS
AC Power Supply with Inverter AC*	-
Correctional Facility	SlideDriver 80 LPS-C
Modular	SlideDriver 80 LPS-M
* 3,000 ft/hr expected duty cycle. The operator's normal duty cycle and the actual number of gate cycles available from battery depends upon gate resistance to travel, cycle length, battery size, state of charge and health, ambient temperature, accessory power draw and frequency of gate cycles during power outage.	
*** SlideDriver 200 UPS has a 2,000 ft/hr (610 m/hr) expected duty cycle. Actual duty cycle depends on site specific conditions and gate configuration.	
*** Refer to Installed Options on pricing for all 50Hz voltages, which are special order.	
* 115V DC Power Supply requires a 30A branch circuit. Choose voltage with care as chargers are not field convertible.	

HySecurity SlideDriver 200	
Capacity	20,000 lb gates 1 ft/s
Model	SlideDriver 200
Part #	444 XLS1
Duty Cycle	Continuous
Horsepower	5 hp/UPS model: 4 hp
Drive	Hydraulic
Drive Wheels	Two 8 inch (20 cm) AdvanceDrive wheels, Two 8 inch XtremeDrive wheels and 52 ft (16 m) of rack
Gate Weight Max.	20,000 lb (9,072 kg)
Gate Length Max.	Limited only by weight
Drawbar Pull	1,200 lb (544 kg)
Rate of Travel	1 ft/s (30 cm/s)
Temperature Rating	-40° to 158°F (-40° to 70° C)
1 Phase Power	230V 60Hz
3 Phase Power	208/230/440V, 220/380/440V 50Hz***
Included Accessories	Pre-wired Hy2NC adapter
Communication	RS-232, RS-485, Ethernet/Fiber using optional HyNet™ Gateway accessory
User Controls	Smart Touch Controller with 70+ configurable settings, programmed via the keypad and display or a PC using S.T.A.R.T. software
Relay	Three configurable user relays: one 30VDC, 3A solid state and two 250VAC, 10A electromechanical; Optional HyRelay™ for 8 additional relay outputs
Finish	Zinc plated with powder coating
UL Listed (UL 325)	Usage Class III, IV
Warranty	5 year w/product registration
UPS Battery Backup Power and Additional Models	
DC Power Supply* 1 with HyCharger DC	SlideDriver 200 UPS**
AC Power Supply with Inverter AC*	-
Correctional Facility	SlideDriver 200-C
Modular	SlideDriver 200-M
* 3,000 ft/hr expected duty cycle. The operator's normal duty cycle and the actual number of gate cycles available from battery depends upon gate resistance to travel, cycle length, battery size, state of charge and health, ambient temperature, accessory power draw and frequency of gate cycles during power outage.	
*** SlideDriver 200 UPS has a 2,000 ft/hr (610 m/hr) expected duty cycle. Actual duty cycle depends on site specific conditions and gate configuration.	
*** Refer to Installed Options on pricing for all 50Hz voltages, which are special order.	
* 115V DC Power Supply requires a 30A branch circuit. Choose voltage with care as chargers are not field convertible.	

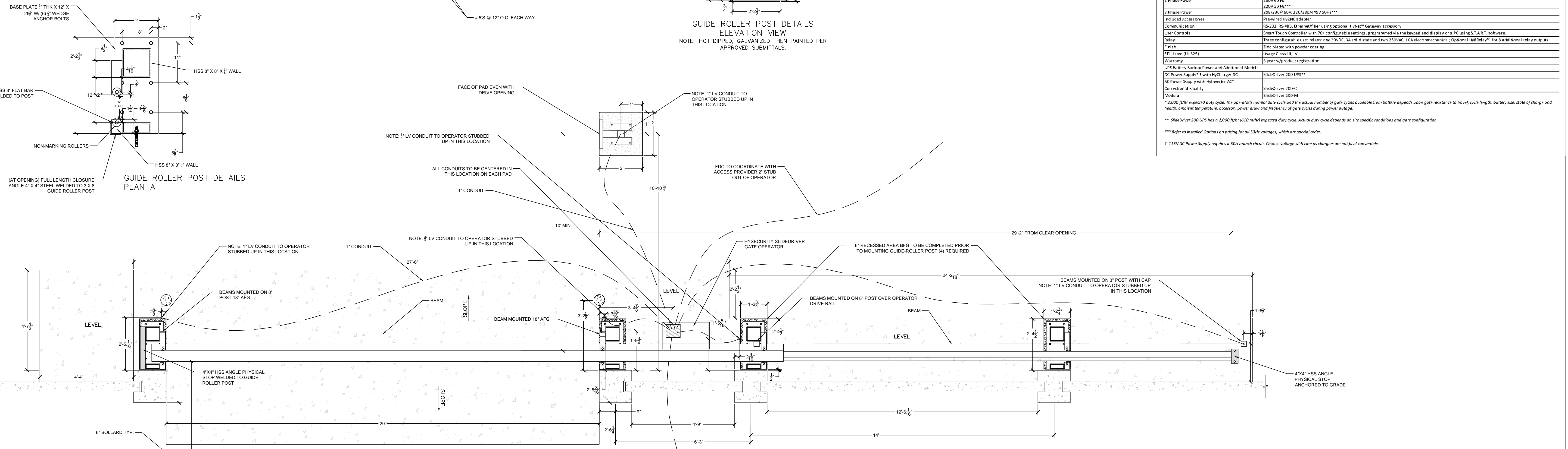

**FDC** Florida Door Control  
Melbourne, FL 32934

FDC STRONGWELD BALLISTIC SLIDE GATE SYSTEM

PART NO.	JOB NO.
DWG. NO. FSBSG1	SCALE N/A BY: BRAWN S.T.
DATE 01/04/2021	SHEET 2 OF 2